

POSITION 34° 44'  
WGS84 135° 21'  
**FURUNO**<sup>®</sup>

34° 44.449' N  
135° 21.219' E

RNG 3.46 nm  
BRG 216°  
SOG 8.4 kt  
COG 206.1°

# GPS

Global Positioning System

Marine GPS Navigator

## GP-150



 The future today with FURUNO's electronics technology.  
**FURUNO ELECTRIC CO., LTD.**  
9-52 Ashihara-cho, Nishinomiya City, Japan Phone: +81 (0)798 65-2111  
Fax: +81 (0)798 65-4200, 66-4622 URL: [www.furuno.co.jp](http://www.furuno.co.jp)

Catalogue No. N-866a

TRADE MARK REGISTERED  
MARCA REGISTRADA

FURUNO GP-150 is a GPS navigator designed for the SOLAS ships according to the GPS performance standard IMO Res MSC.112(73) and associated IEC standards effective on and after July 1, 2003. It is a highly reliable standalone EPFS (electronic position fixing system) that feeds positioning information to AIS, Radar, VDR, ECDIS, Autopilot, Echo Sounder and Sonar.

Receiver dependability is improved by fault detection using five satellites, i.e., Receiver Autonomous Integrity Monitoring (RAIM) that shows the integrity status in Safe, Caution, and Unsafe levels. The status is given with respect to user selected accuracy level, 10 m or 100 m. RAIM also works on DGPS signals.

## GP-150 MARINE GPS NAVIGATOR



Display Unit



GPS/WAAS Antenna:



DGPS Antenna:

In order to improve position accuracy, WAAS and DGPS\* augmentation systems are available. Dual configuration, with a second system, provides a backup and/or remote operation to ensure system availability.

\*Internal or external beacon receiver is required for utilizing DGPS.



# Compliant for SOLAS carriage requirements as a display device and as a sensor for AIS, Radar, VDR, etc.

- ▶ Fully meets new IMO Resolution MSC.112(73) and IEC 61108-1 Ed.2 for SOLAS carriage requirements on and after 1 July 2003
- ▶ Ideal sensor of SOG and COG for AIS, radars, and other navigational aids
- ▶ Augmentation to enhance accuracy by standard fitted WAAS and optional DGPS
- ▶ Display modes: VideoPlotter, 3-D Highway, Text, Steering.
- ▶ Memory: 2,000 points for ship's past positions and marks (incl. 99 event marks max.); 999 waypoints; 30 routes each containing up to 30 waypoints

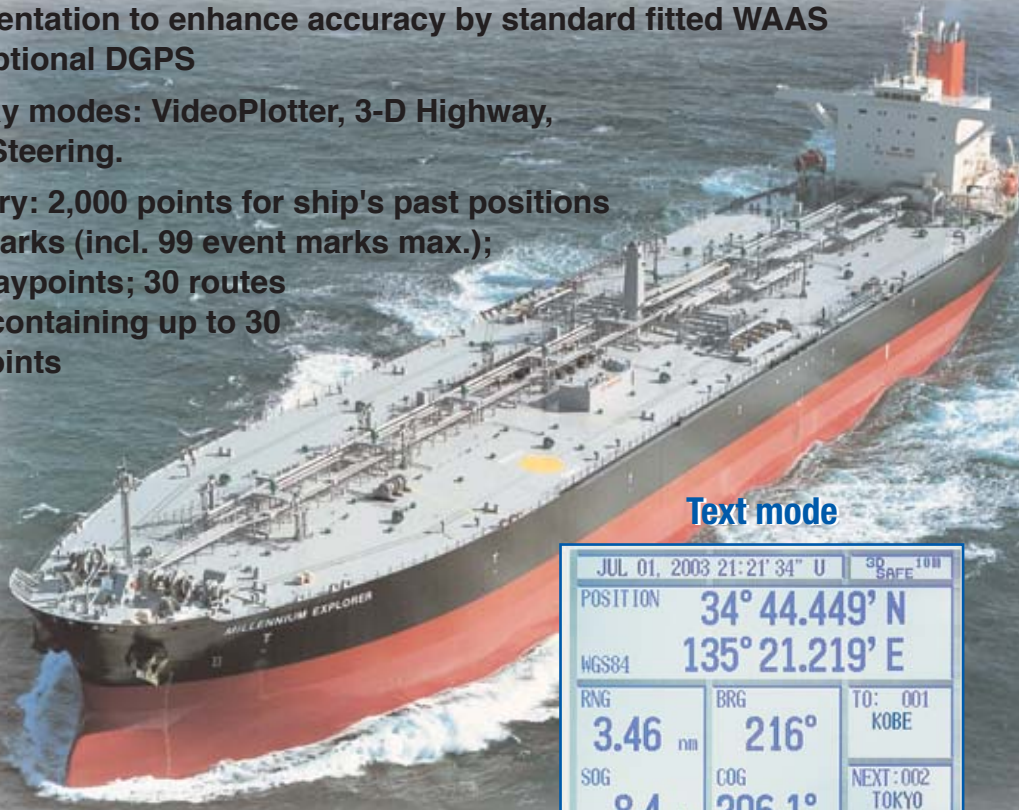

Text mode



Highway mode

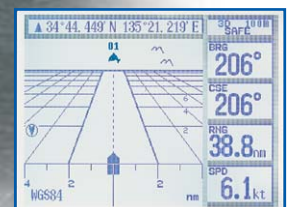

VideoPlotter mode

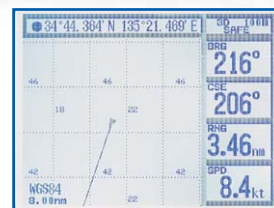

Steering mode

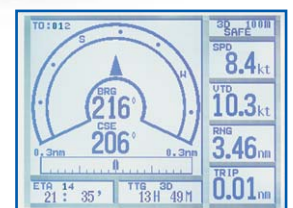

Display mode is selectable from VideoPlotter, Text, Highway and Steering. In the Highway mode, you can intuitively see how to steer and where the next waypoint is located relative to your ship. It is useful when you are following a series of waypoints along a planned route.

The SOLAS Chapter V as amended in December 2000 prohibits new installation of current GPS receivers which are designed to meet IMO A.819 on and after 1 July 2003\*. With the comparison table, you will see why we say the new IMO equipment is epoch making.

	MSC.112(73), IEC 61108-1 ed.2	A.819(19), IEC 61108-1 ed.1
Accuracy	13 m (95%)	100 m (95%)
SOG (speed over ground)	Required to accuracy of SDME	SOG prohibited, no testing standard
COG (course over ground)	Required to accuracy of $\pm 1^\circ$ ( $>17$ kt), $\pm 3^\circ$ ( $<17$ kt)	COG prohibited, no testing standard
UTC	Required to output	Data is limited to only L/L
RAIM (Receiver autonomous integrity monitoring)	Required to indicate integrity indication of Safe, Caution, Unsafe at confidence level of 10 m and 100 m	No
Display update rate	1 second at latest	every 2 second

\* Some Administrations may give a grace period for the current GPS receivers.

## SPECIFICATIONS

### GPS

Receiver	12 discrete channels all-in-view, C/A code
RX Frequency	L1 (1575.42 MHz)
Time to First Fix	12 Second (Warm start)
Tracking Velocity	900 kt
Geodetic System	WGS-84 (NAD-27 or others selectable)
Update Rate	1 Second

### Positioning Augmentation

#### DGPS

Reference Station:	Automatic or manual selection
Frequency Range:	283.5 - 325.0 kHz (all ITU regions)
Format:	RTCM SC-104 Ver 2.0 Type1, 7, 9, 16

#### WAAS

WAAS augmentation is available through the GPS core in the display unit

### Accuracy

GPS:	10 m (95%)
DGPS:	5 m (95%)
WAAS:	3 m (95%), limited coverage
SOG:	±0.2 kt (SOG ≤ 10 kt)
COG:	±3° (SOG 1-17 kt), ±1° (SOG > 17 kt)

### Display

6" LCD (120 x 91 mm),  
320 (H) x 240 (V) pixels,  
L/L resolution: 0.001 min

### Display Modes

VideoPlotter, Highway, Text, Steering

### VideoPlotter

Scale:	0.02 to 320.0 nm,
Plot Interval:	1 s - 60 min or 0.01-99.99 nm

### Memory Capacity

2,000 points for ship's track and marks, 999 waypoints with comments, 30 routes (containing 30 waypoints/route)

### Alarms

Arrival, anchor watch, XTE, Speed, Time, Water Depth, Trip, DGPS, WAAS

### Integrity indication

Safe, Caution, Unsafe at accuracy level of 10 m or 100 m

### Interface (IEC 61162-1 Ed 2, NMEA 0183)

Output	GBS (satellite fault), GLL (L/L), VTG (SOG, COG), ZDA(UTC), WPL (WPT location), etc.
Input	DBT (Depth), HDT (Compass), MTW (Water temperature), TLL (TGT L/L), VBW (Dual grd/wat spd), etc.

### ENVIRONMENT (IEC 60945 test method)

Temperature	Display Unit: -15°C to +55°C Antenna Unit: -25°C to +70°C
Waterproofing	Display Unit: IPX5 (IEC 60529) Antenna Unit: IPX6 (IEC 60529)
EMC	IEC 60945 Ed. 4 (up to 2 GHz)

### POWER SUPPLY

12-24 VDC, 0.8-0.4 A

## EQUIPMENT LIST

### Standard

1. Display Unit (Specify single or dual)	1 unit
2. Antenna Unit GPA-017S GPA-018S* GPA-019S*	1 unit
(specify when ordering)	
*Selectable when a beacon receiver is incorporated into a display unit.	
3. Antenna Cable	15 m
4. Interface Cable	5 m x 2 pcs
5. Installation Materials and Spare Parts	1 set

### Option

- DGPS Receiver Kit OP20-32-1/20-33
- Whip Antenna FAW-1.2 for GPA-018S
- Antenna Cable, 30/50 m
- Interface Cable, 5/10 m
- Antenna Base  
CP20-01111 (Pipe mount), No.13-QA330 (Deck mount)  
No.13-QA310 (Offset bracket), No.13-RC5160 (Handrail mount)
- Flush Mount Kit OP20-24/20-25
- Interface Unit IF-2500
- External DGPS Receiver GR-80
- Rectifier PR-62

### Antenna Unit

GPA-017S  
0.15 kg 0.3 lb

GPA-018S  
0.3 kg 0.7 lb

GPA-019S  
1.0 kg 2.2 lb

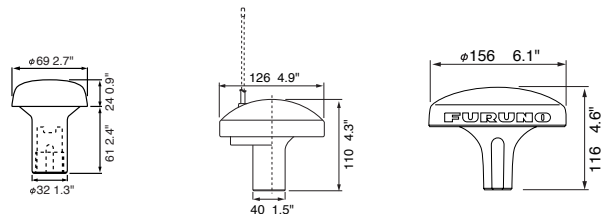

### Display Unit

2.2 kg 4.9 lb

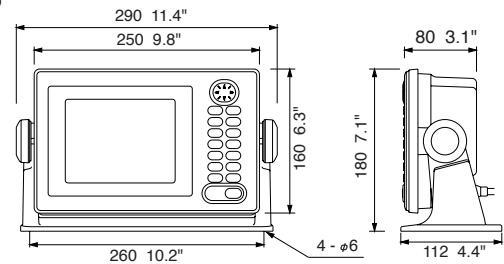

## Interconnection Diagram

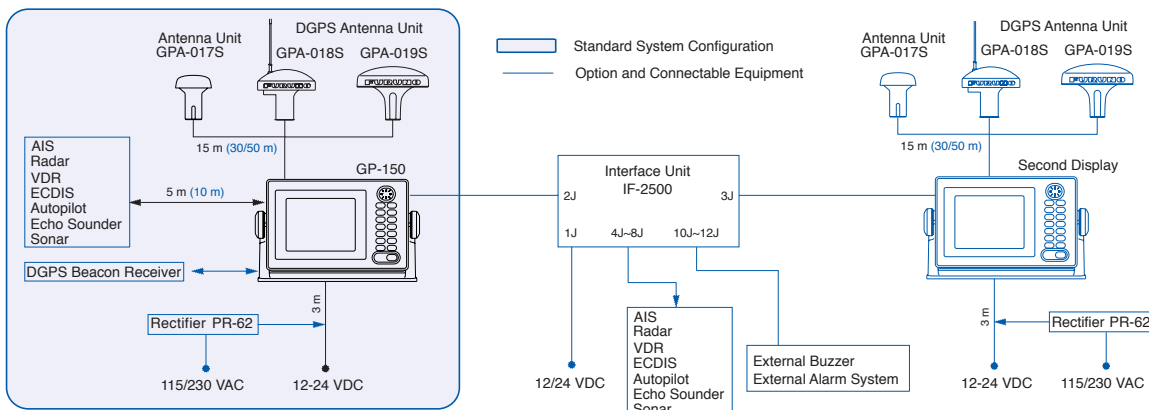

TRADE MARK REGISTERED MARCA REGISTRADA  
SPECIFICATIONS SUBJECT TO CHANGE WITHOUT NOTICE

### FURUNO U.S.A., INC.

Camas, Washington, U.S.A.  
Phone: +1 360-834-9300  
Fax: +1 360-834-9400

### FURUNO (UK) LIMITED

Denmead, Hampshire, U.K.  
Phone: +44 2392-230303  
Fax: +44 2392-230101

### FURUNO FRANCE S.A.

Bordeaux-Mérignac, France  
Phone: +33 5 56 13 48 00  
Fax: +33 5 56 13 48 01

### FURUNO ESPAÑA S.A.

Madrid, Spain  
Phone: +34 91-725-90-88  
Fax: +34 91-725-98-97

### FURUNO DANMARK AS

Hvidovre, Denmark  
Phone: +45 36 77 45 00  
Fax: +45 36 77 45 01

### FURUNO NORGE A/S

Ålesund, Norway  
Phone: +47 70 102950  
Fax: +47 70 102951

### FURUNO SVERIGE AB

Västra Frölunda, Sweden  
Phone: +46 31-7098940  
Fax: +46 31-497093

### FURUNO FINLAND OY

Espoo, Finland  
Phone: +358 9 4355 670  
Fax: +358 9 4355 6710

### FURUNO POLSKA Sp. z o.o.

Gdynia, Poland  
Phone: +48 58 669 02 20  
Fax: +48 58 669 02 21

### FURUNO DEUTSCHLAND GmbH

Rellingen, Germany  
Phone: +49 4101 838 0  
Fax: +49 4101 838 111

### LLC "FURUNO EURUS"

Petersburg, Russia  
Phone: +7 812 767 15 92  
Fax: +7 812 766 55 52

06085SS Printed in Japan

